

## Racks

*The Dagard shark's bar rack is designed for small meat businesses for hanging up meat products of all types.*

*Assembly is fast and easy with its ready-to-assemble components.*

*2 other models are available : galvanized or stainless steel frame with hanging bars systematically in stainless steel.*

### Technical characteristics

Height : 215 cm

Dimensions :

Rack dimensions are adapted to cold rooms from 120 x 160 cm to 320 x 320 cm

Structure:

Galvanized frame racks are made up of uprights, upper bars and intermediary bars in galvanized steel with hanging bars in stainless steel.

All the components of stainless steel racks are made of stainless steel.

Connecting pieces are made of aluminum alloy.

Hanging bars :

With hooks or smooth, in stainless steel (50 x 10 mm)

Number of hooks : 6 per ml

Mounting :

Bars and uprights are cut to length with predrilled holes for ease of assembly.

You are advise to build the rack on a concrete pavement in a room without floor.

We cannot guarantee the mechanical strength of our floor panels subjected to weights and loads on racks.

Admissible loads:

On one hook : 120 kg

On one bar : 350 kg on bar 2 ml



on wall

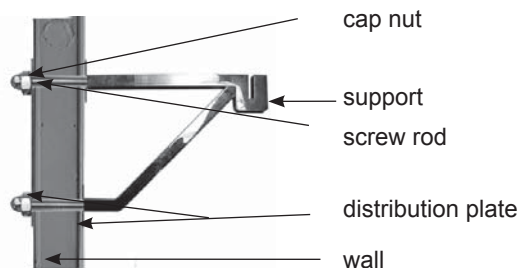

on ceiling

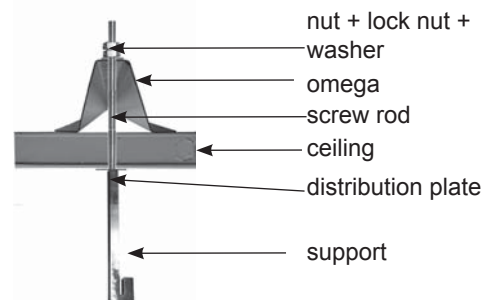

To select best rack option for your needs (stainless steel or galvanized frame), please contact the competent veterinary authorities at the site of installation of the rack.

# Accessories

## Basic principle of assembly

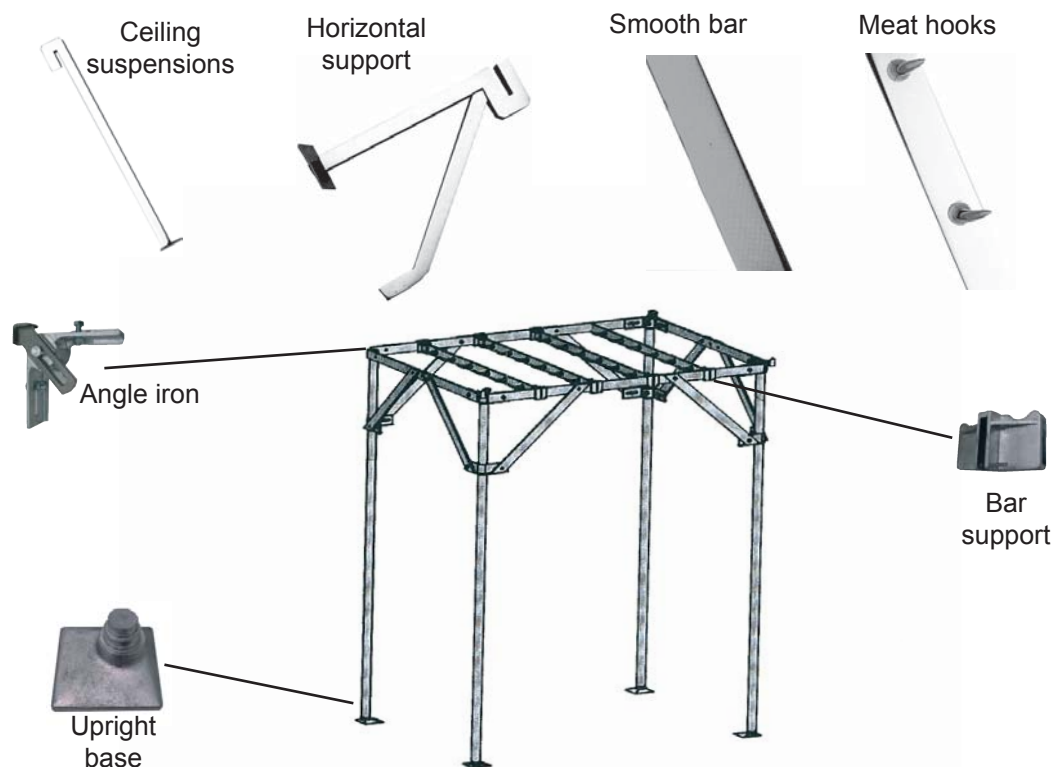

For spans in excess of 2 m, the rack is reinforced by two intermediary uprights (with the two accessories opposite : upright brace, double bar brace).



## Hanging elements

Ring hooks



S-shaped hooks



Liding hooks



Documentation available on [www.dagard.com](http://www.dagard.com)



Your distributor

